

Product Specification

SL-9

Item

Specification

Product Code  
 NOTE : Hub Serial No. : 9-A1  
 99999 , Font size : 1.4 mm.  
 Serial No.

Laser etching way: Both sides with different patterns, which should follow the drawing.

Axle Fixing Bolt	QR
Spoke Hole	20/24/28/32/36
Seal	Bearing*2
Output Volage	6V1.5W/LED
Wheel Diameter	400~658mm
Weight	323g
Dynamo	MD004

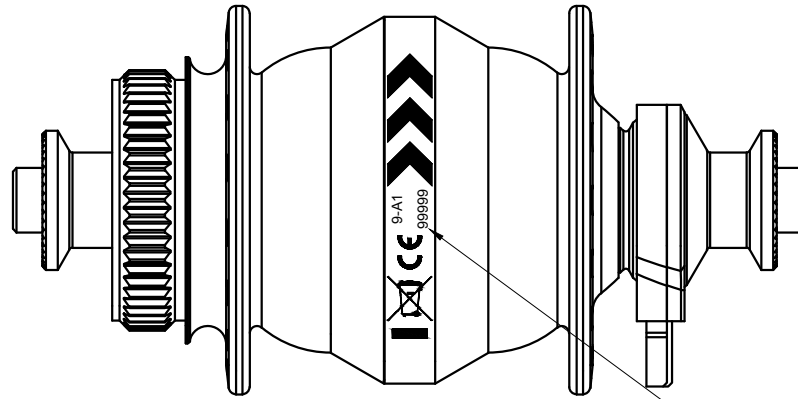

Electric wire

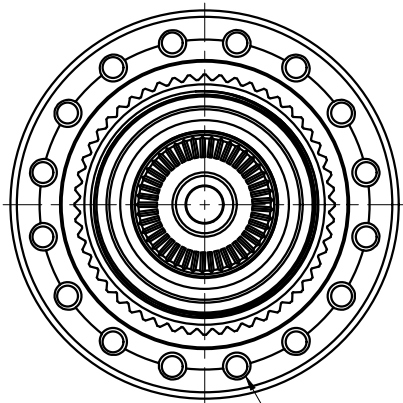
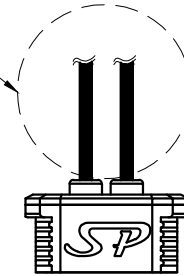

Spoke Hole  
 $\varnothing 2.7^{+0.1}_{+0.05}$ -PCD $\varnothing 45$

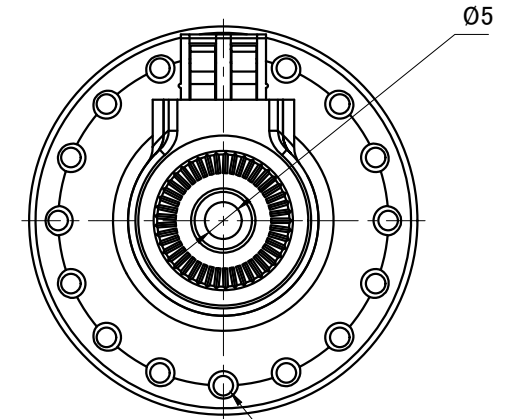
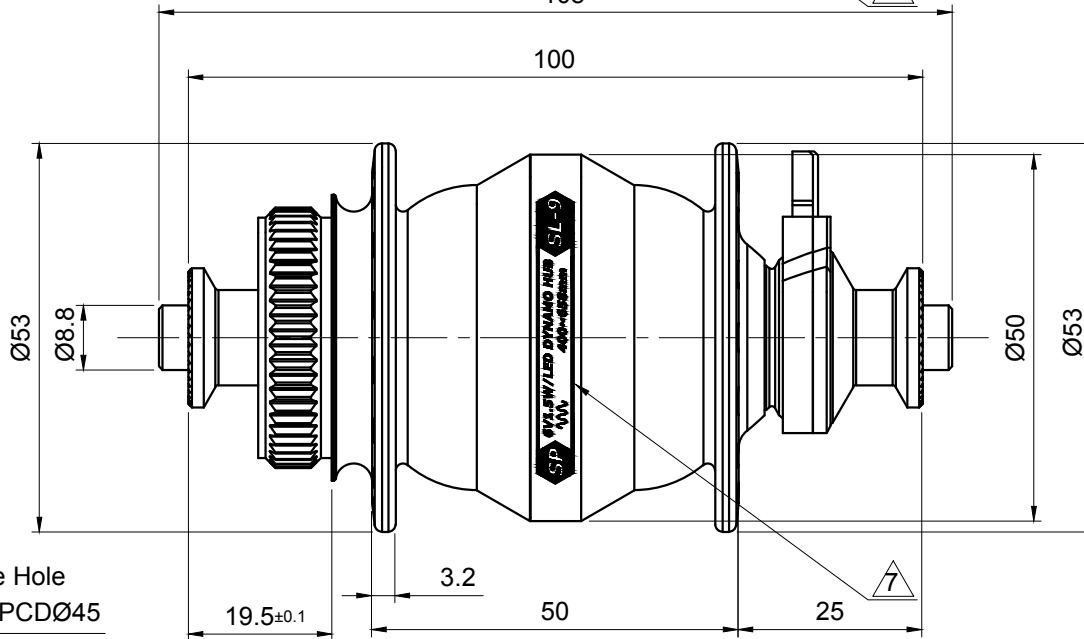

Spoke Hole  
 $\varnothing 2.7^{+0.1}_{+0.05}$  - PCD $\varnothing 45$

Version Date: 2020.12.17

				UNIT:mm	SCALE	TOLERANCE	Hub dynamo	
$\triangle 7$	2020.12.17		Laser etching way is change		1 : 1	±0.5	SP Model	
$\triangle 6$	2020.07.21		Laser etching way is change				SL-9	
$\triangle 5$	2016.02.25		Modification of part no. and design	MAKE	CHECK	CONFORM	MODEL	
$\triangle$	Version Date	ECR No.	Description	<b>SL-9-07</b>				