

Product Specification

PL-8X

Item

Specification

NOTE : Hub Serial No. : 8XA1
99999 , Font size : 1.4 mm.
Product Code
Serial No.

Laser etching way: Both sides with different patterns, which should follow the drawing.

Axle Fixing Bolt	QR
Spoke Hole	32 / 36
Seal	Bearing *2
Output Volage	6V3W
Wheel Diameter	646~716mm
Weight	468g
Dynamo	MD003

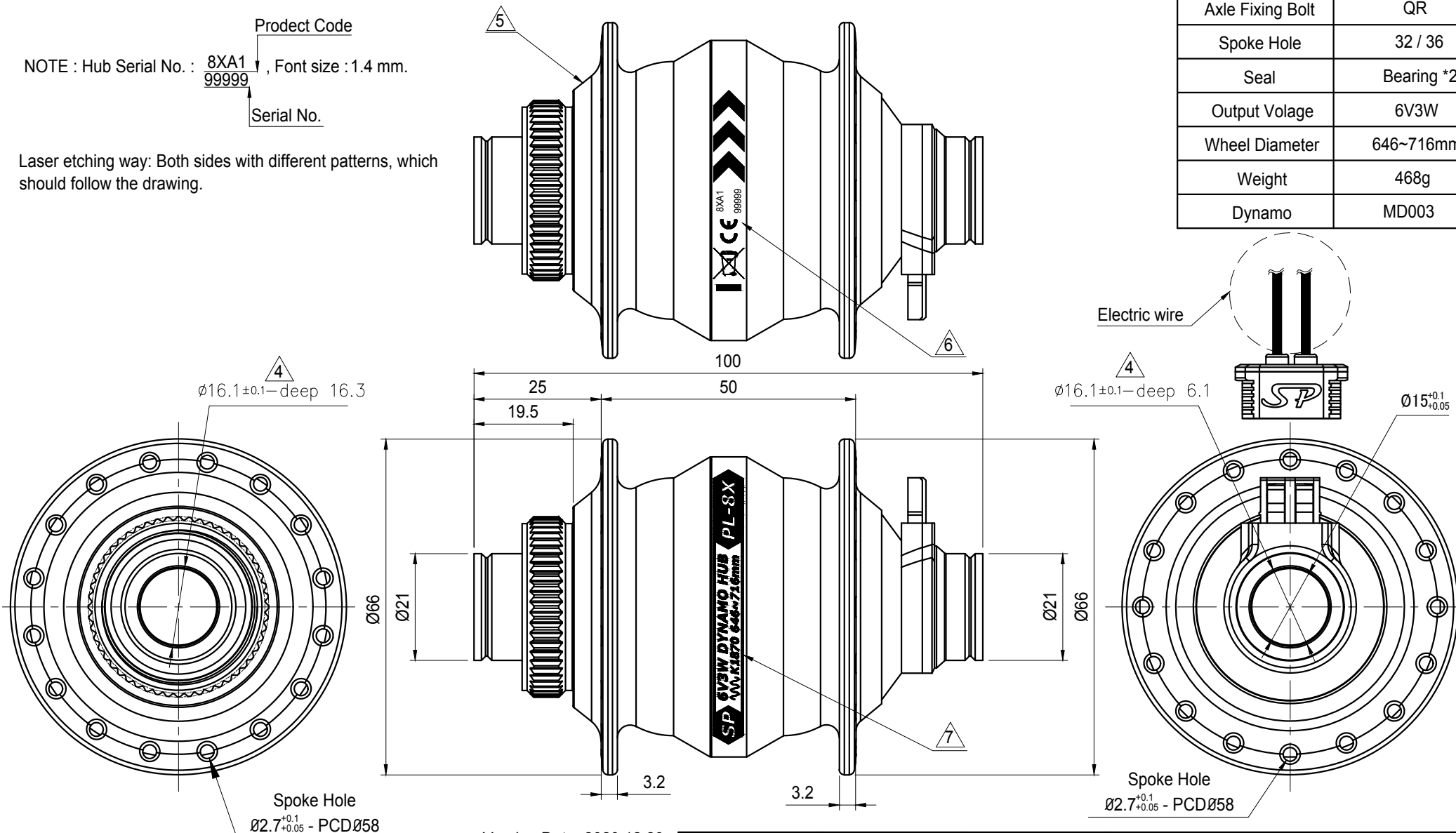

Version Date: 2020.12.29

7	2020.12.29		Laser etching way is change
6	2020.07.21		Laser etching way is change
5	2019.05.15		Modification of shape
4	2017.05.12		Dimensions marked
	Version Date	ECR No.	Description

UNIT:mm	SCALE	TOLERANCE
	1:1	± 0.5
MAKE	CHECK	CONFORM

Hub dynamo	
SP Model	8X Series
MODEL	
PL-8X-07	