

Laser etching way: Both sides with different patterns, which should follow the drawing.

Item	Specification
Axle Fixing Bolt	QR
Spoke Hole	32 / 36
Seal	Bearing *2
Output Voltage	6V3W
Wheel Diameter	646~716mm
Weight	¹ 409g
Dynamo	MD005

NOTE : Hub Serial No. : $\frac{7-A1}{99999}$, Font size : 1.4 mm.
 Prodict Code
 Serial No.

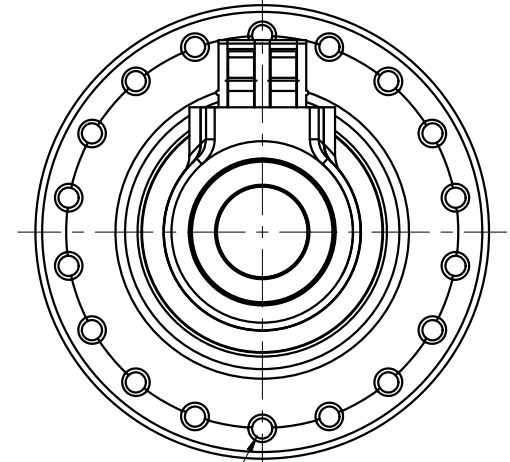
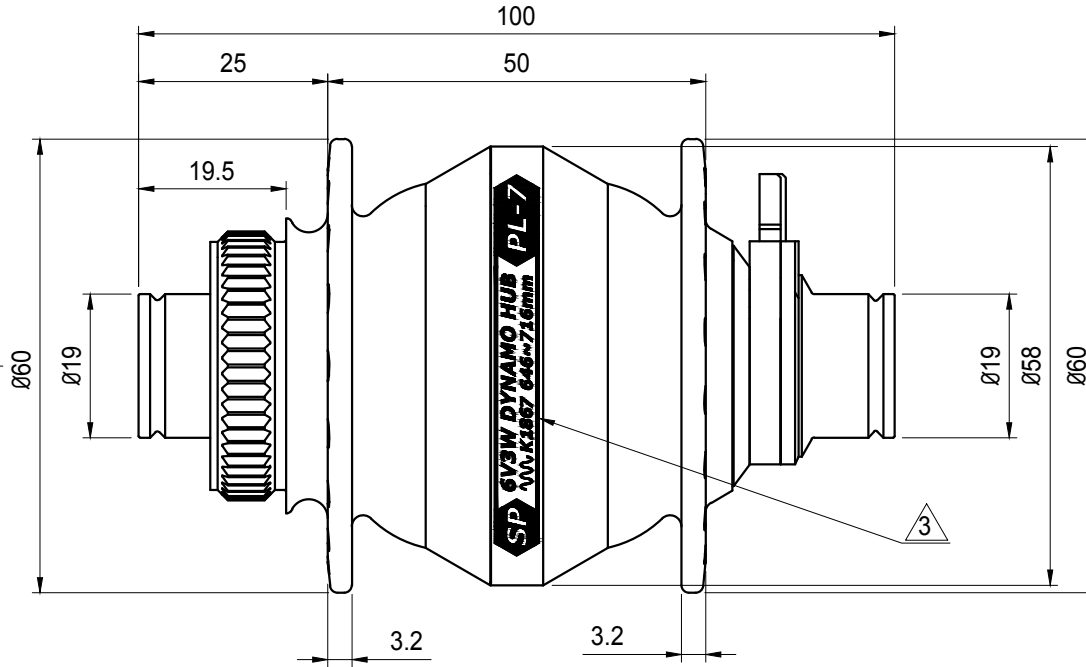
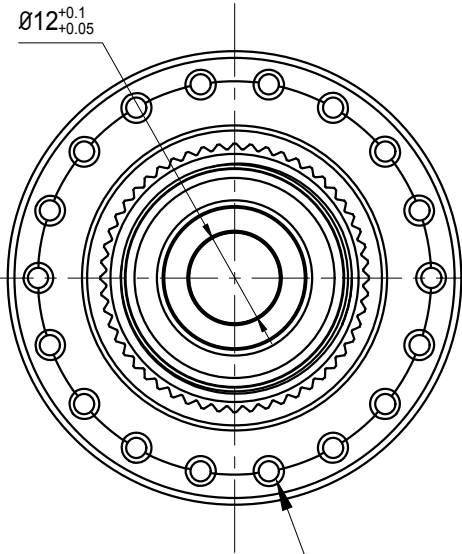
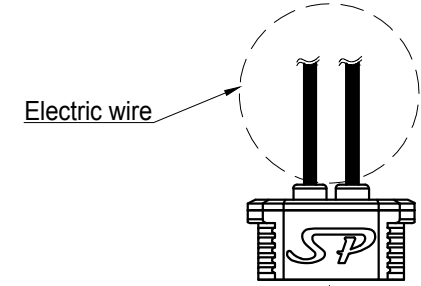
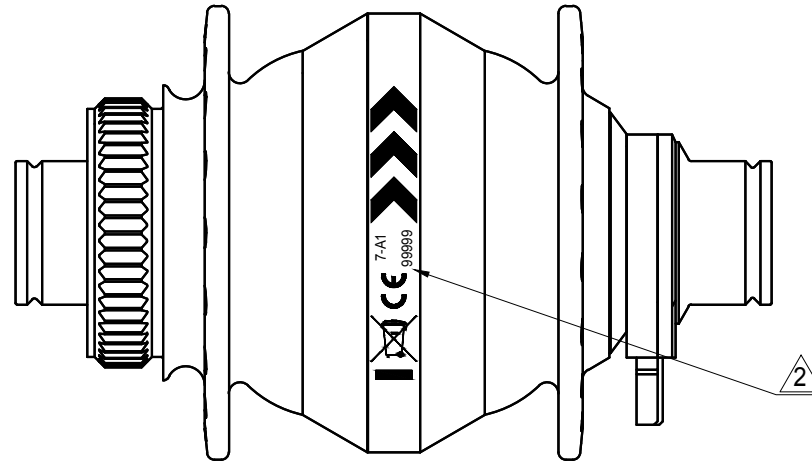

Spoke Hole
 $\varnothing 2.7^{+0.1}_{+0.05}$ - PCD $\varnothing 52$

Spoke Hole
 $\varnothing 2.7^{+0.1}_{+0.05}$ - PCD $\varnothing 52$

Version Date: 2020.12.29

UNIT:mm	SCALE	TOLERANCE
	1:1	± 0.5
MAKE	CHECK	CONFORM

Hub dynamo	
SP Model	7 Series
MODEL	
PL-7-03	

³	Version Date	ECR No.	Description
³	2020.12.29		Laser etching way is change
²	2020.07.21		Laser etching way is change
¹	2018.10.26		Modification of weight from 395g to 409g