

Product Specification

PD-8X-150

Item Specification

Product Code  
 NOTE : Hub Serial No. : 8XA1 99999, Font size : 1.4 mm.  
 Serial No.

Laser etching way: Both sides with different patterns, which should follow the drawing.

Axle Fixing Bolt	QR
Spoke Hole	32 / 36
Seal	Bearing *2
Output Volage	6V3W
Wheel Diameter	646~716mm
Weight	530g $\triangle 7$
Dynamo	MD003

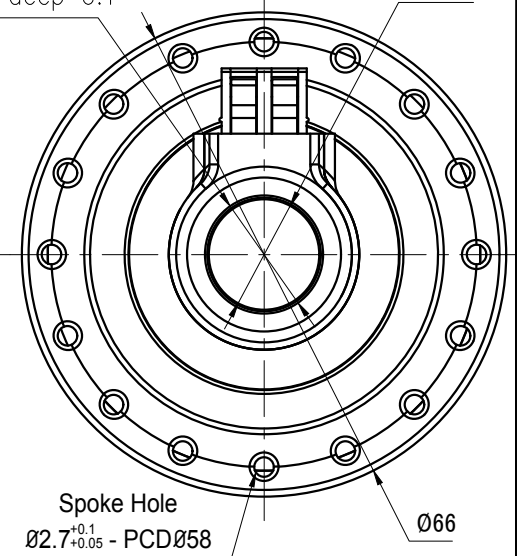
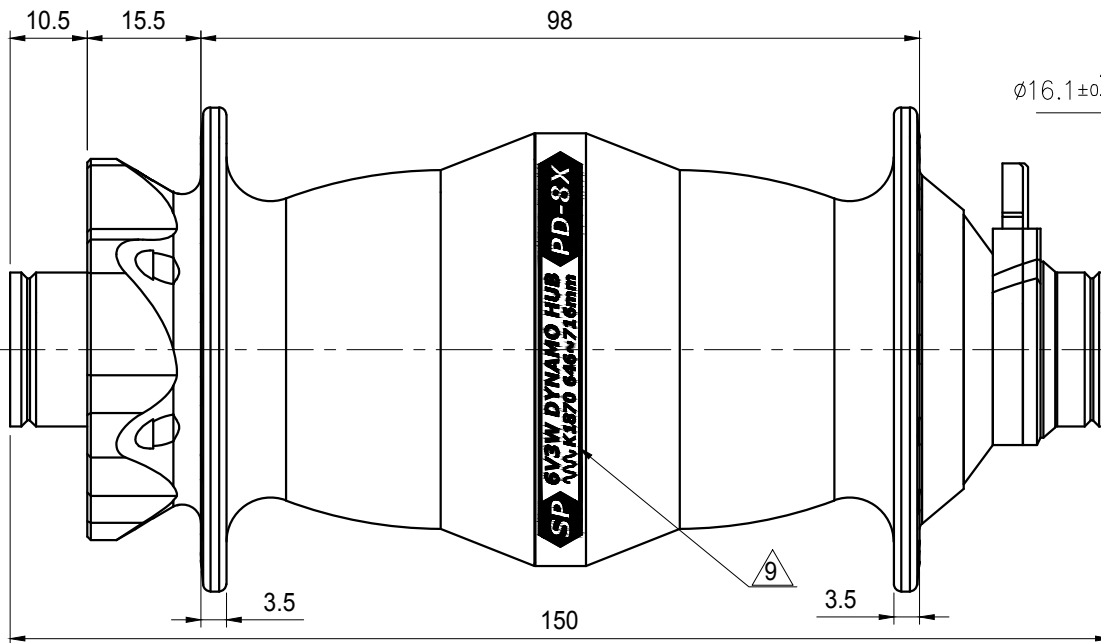
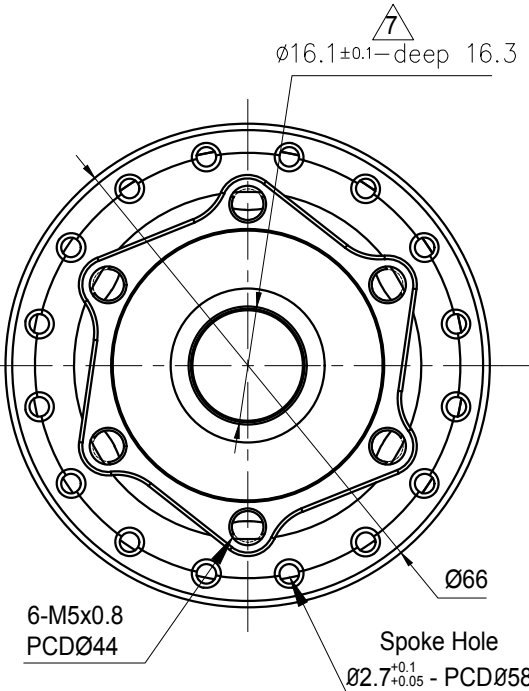
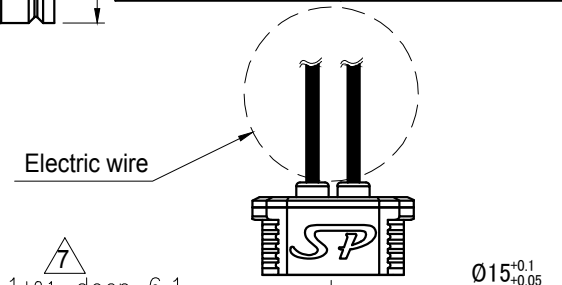
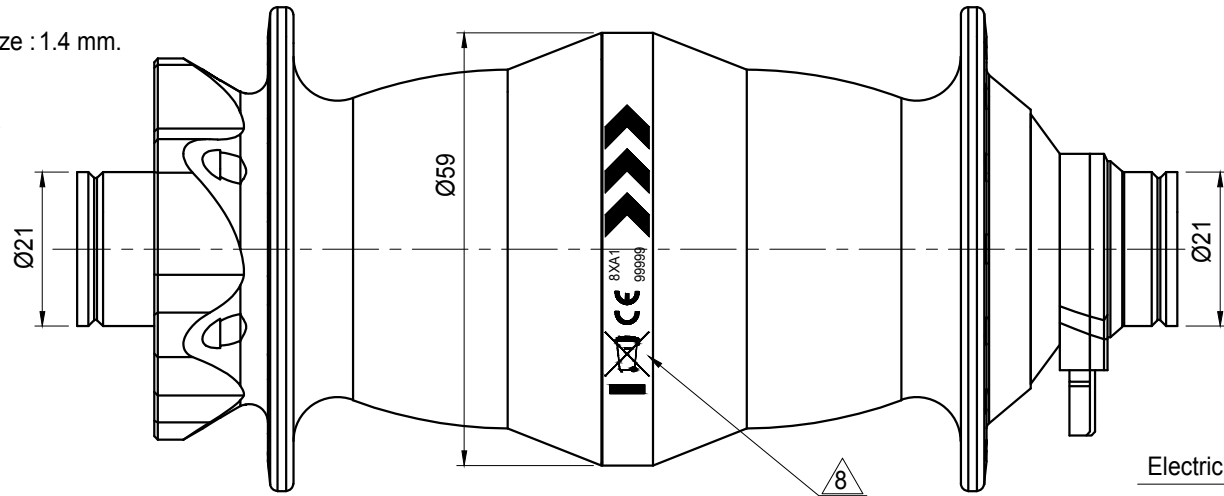

Version Date: 2020.12.29

$\triangle 9$	2020.12.29		Laser etching way is change
$\triangle 8$	2020.07.21		Laser etching way is change
$\triangle 7$	2017.05.12		Dimensions marked and modification of weight
$\triangle 6$	2016.11.28		Modification of disc brake mechanism shape and part design
$\triangle$	Version Date	ECR No.	Description

UNIT:mm	SCALE	TOLERANCE
	1:1	$\pm 0.5$
MAKE	CHECK	CONFORM

Hub dynamo	
SP Model	8X Series
MODEL PD-8X-150-09	